

RAVAS-1

Pallet truck load indication system

BENEFITS

- Attractively priced entry model
- Virtually indestructible
- Water tight: for use onboard lorries
- Standard fork dimensions

Top quality

Great value for money

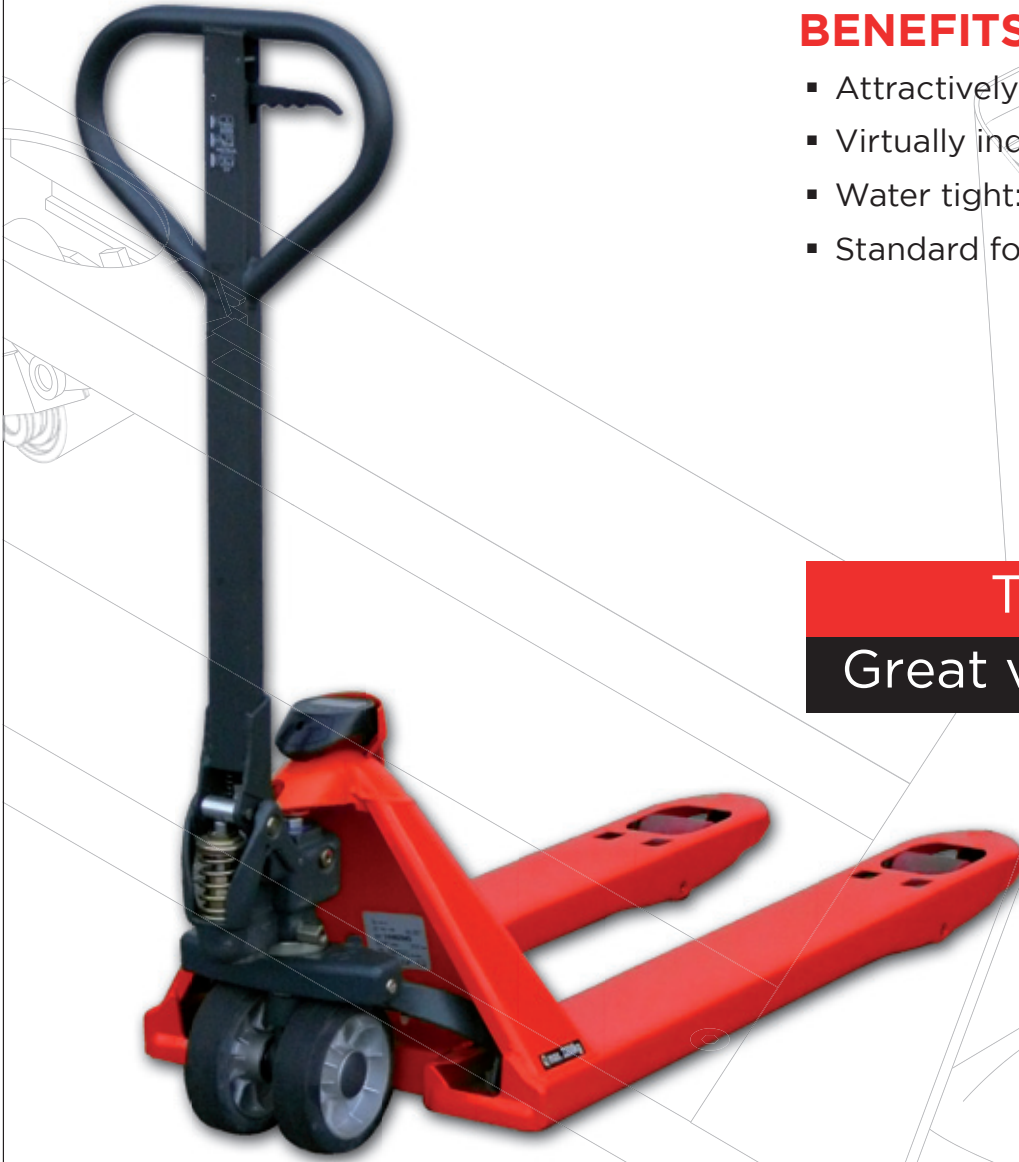

RAVAS

FUNCTIONS

- Manual zero correction
- Totalling with sequence number
- Lifting height indication in display
- Error messages in display
- Automatic switch-off

STANDARD SPECIFICATIONS

- Weighing capacity 2,200 kg
- Graduation 5 kg
- Tolerance 0.8% of full scale
- Display LCD
- Keypad 2 function keys
- Protection class IP65
- Steering wheels rubber
- Loading wheels polyurethane, single
- Colour red (RAL 3000), epoxy painted
- Own weight 58 kg
- Power supply 2 AA-batteries
- Battery life 3,000 on/off weighing cycles of three minutes: automatic switch-off after 2 minutes
- Pump quick lift

DIMENSIONS IN MM

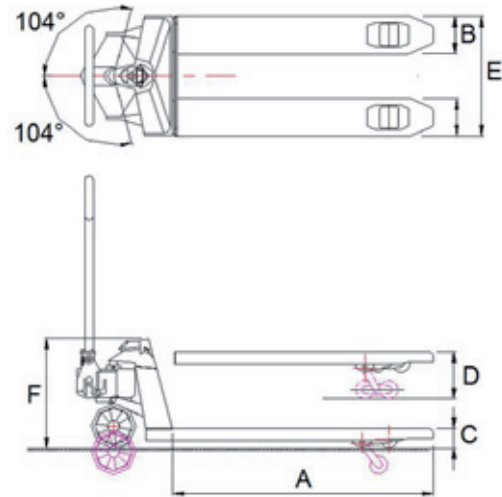

A Fork length	1150
B Fork width	150
C Minimum fork height	83
Minimum space between floor and forks	30
D Maximum fork height	205
Lifting height	122
E Width over forks	520
F Height to top indicator	495



PREMIUM OPTIONS*

- Tandem loading wheels in polyurethane
- Footbrake

* The use of options may change related specifications.

RAVAS Europe B.V.

P.O. Box 2023, NL-5300 CA Zaltbommel, The Netherlands
 T. +31 (0)418 51 52 20, F. +31 (0)418-51 53 20
 backoffice@ravas.com, www.ravas.com

RAVAS