



**KERN & Sohn GmbH**

Ziegelei 1

D-72336 Balingen

E-Mail: [info@kern-sohn.com](mailto:info@kern-sohn.com)

Phone: +49-[0]7433- 9933-0

Fax: +49-[0]7433-9933-149

Internet: [www.kern-sohn.com](http://www.kern-sohn.com)

## Operating manual Electronic Crane Scales

Logbook  
Regular maintenance and care

### KERN HTS-A

Version 3.0

11/2014

GB



HTS-A-BA-e-1430



---

---

# KERN HTS-A

Version 3.0 11/2014

## Operating instructions / logbook Electronic Crane Scales

---

---

### Contents

<b>1.</b>	<b>Technical data</b> .....	4
1.1	Dimensions (mm) .....	5
<b>2.</b>	<b>General Safety Instructions</b> .....	6
2.1	Duties of the owner-operator .....	6
2.2	Organizational measures .....	6
2.3	Environmental conditions .....	6
2.4	Proper use .....	7
2.5	Improper Use .....	7
2.6	Warranty .....	7
2.7	Safe working .....	8
2.8	Monitoring of Test Resources .....	8
2.9	Testing upon acceptance .....	8
2.10	Initial Commissioning .....	8
2.11	Shutdown and storage .....	8
<b>3.</b>	<b>The crane scales at a glance</b> .....	9
3.1	Overview .....	9
3.2	Display .....	10
3.3	Keyboard .....	10
3.5	Infrared remote control unit .....	11
3.6	Label .....	12
<b>4.</b>	<b>Commissioning</b> .....	13
4.1	Unpacking .....	13
4.2	Installing a precision fuse .....	13
4.3	Checking the original dimensions .....	14
4.4	Rechargeable battery operation .....	14
4.5	Suspending the balance .....	15

<b>5.</b>	<b>Operation</b>	16
5.1	Safety instructions	16
5.2	Loading the crane scales	17
5.3	Turn on/off	20
5.4	Set balance to zero	21
5.5	Taring	22
5.6	Weighing	22
5.7	Gross / net invocation	22
5.8	Display background illumination	22
<b>7.</b>	<b>Adjustment and verification</b>	23
7.1	Adjustment	23
7.2	Verification	24
<b>8.</b>	<b>Error messages</b>	25
<b>9.</b>	<b>Cleaning and Disposal</b>	25
9.1	Cleaning and Disposal	25
<b>10.</b>	<b>Maintenance and repair</b>	26
10.1	Regular maintenance and care	26
10.2	Regular maintenance	27
10.3	Checklist „Regular maintenance“, (see chapter 10.2)	28
<b>11.</b>	<b>Enclosure</b>	31
11.1	Checklist „Enhanced maintenance“ (General revision)	31
11.2	List „spare parts and repair of safety-relevant parts“	32

## 1. Technical data

<b>KERN</b>	<b>HTS 1T-4AM</b>	<b>HTS 3T-3AM</b>	<b>HTS 6T-3AM</b>	<b>HTS 10T-3AM</b>
Readability (d)	500 g	1 kg	2 kg	5 kg
Weighing range (max)	1 500 kg	3 000 kg	6 000 kg	10 000 kg
Taring range (subtractive)	1 000 kg	3 000 kg	6 000 kg	10 000 kg
Minimum weight (min)	10 kg	20 kg	40 kg	100 kg
Verification value (e)	500 g	1 kg	2 kg	5 kg
Verification class	III			
Reproducibility	500 g	1 kg	2 kg	5 kg
Linearity	± 1 kg	± 2 kg	± 4 kg	± 10 kg
Recommended adjustment weight, not added (class)	1.5 t (M2)	3 t (M2)	6 t (M2)	10 t (M2)
Stabilization time	2 s			
Warm-up time	10 min			
Unit	kg			
Allowable ambient temperature	-20...+50 °C			
Relative humidity	10 to 95 %, non-condensing			
Input voltage Appliance	110V - 230V AC			
Input voltage Mains adapter	9V, 800 mA			
Rechargeable battery (standard equipment)	6 V 3.2 A Service life 100 h (background light on) Loading time 12 h			
Display	Digit height 25 mm			
Housing size W x D x H, (mm)	270x175x200	270x175x200	300x190x230	300x190x230
Housing material	Alu casting, varnished			
Material hooks and shackle	Forged steel			
Net weight (kg)	6.5	8.5	12.0	20.0
Infrared remote control unit (standard equipment)	Block battery 9V 48 x 16 x 95 mm (W x D x H) Range approx. 10 m			

### 1.1 Dimensions (mm)

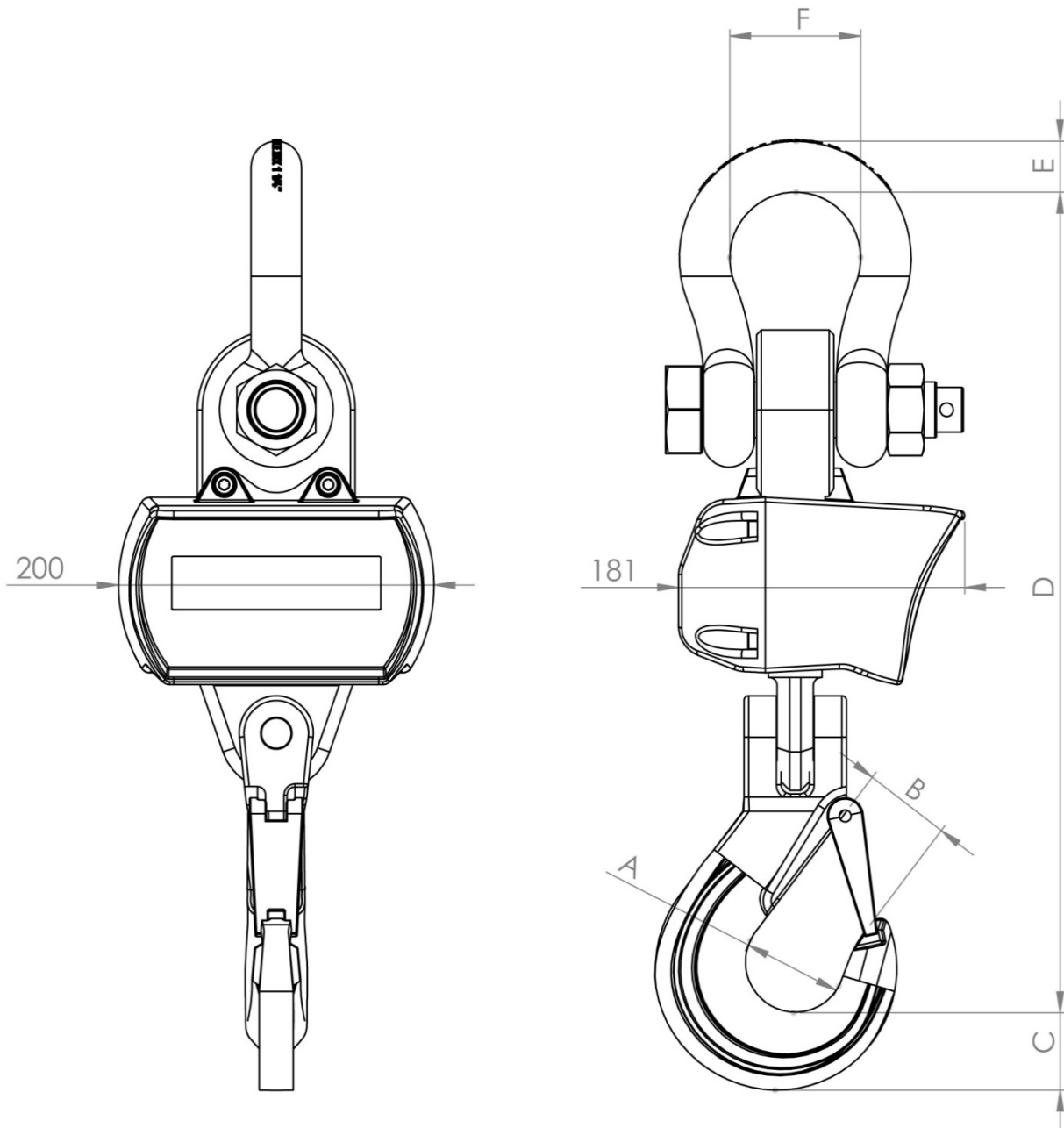

	<b>A</b>	<b>B</b>	<b>C</b>	<b>D</b>	<b>E</b>	<b>F</b>
HTS 1T-4AM	37	29	32.5	314.6	12.7	33.3
HTS 3T-3AM	56	47	42.5	346.75	17.5	42.9
HTS 6T-3AM	60	55	54	440	24.6	58
HTS 10T-3AM	79	61	58	535.35	35	82.6

## **2. General Safety Instructions**

### **2.1 Duties of the owner-operator**

Follow national accident prevention regulations and all operator health and safety at work and operating regulations.

- Observe all safety regulations of the crane manufacturer.
- The balance may only be used for the proposed purpose. Any type of use which is not specified in these operating instructions, will be considered as improper use. The customer is solely responsible for material damage and injury of persons resulting from an improper use, Messrs. KERN & Sohn will not be liable under any circumstance.

Messrs. KERN & Sohn cannot be held liable, if the crane scales are modified or used improperly and if damage is resulting from such use.

- Inspect and service crane balance, crane and load suspension devices regularly (see chap. 10).
- Log the test result and keep it in the logbook.

### **2.2 Organizational measures**

- Only trained and instructed staff may operate the balance.
- Make sure that the operating instructions are kept nearby the operation site of the crane scales.
- Assembly, commissioning and maintenance should only be carried out by trained specialists.
- Repair of safety-relevant pieces may only be carried out by KERN or by service partners authorized by Messrs. KERN. (competence certificate or training).
- Use original spare parts only.
- All repairs and spare parts must be documented by the service partner (see list, chap. 11.2).
- All maintenance must be documented (see checklist chap. 10.3).
- Load suspending components may only be exchanged as a complete spare parts set. The dimensions of the new components must be noted (see checklist chapter 10.3).

### **2.3 Environmental conditions**

- Never operate the crane scales in explosive environment. The serial version is not explosion protected.
- Operate the crane scales only under environmental conditions as specified in these operating instructions (especially in chapter 1 „Technical data“).
- Do not expose the crane scales to strong humidity. Non-permitted condensation (condensation of air humidity on the appliance) may occur if a cold appliance is taken to a considerably warmer environment. In this case, acclimatize the disconnected appliance for ca. 2 hours at room temperature.
- Do not operate the crane scales in corrosive environment.
- Protect the crane scales against high humidity, vapours and dust.

- Major display deviations (incorrect weighing results) may be experienced should electromagnetic fields (e.g. due to mobile phones or radio equipment), static electricity accumulations or instable power supply occur. Change location or remove source of interference.

## 2.4 Proper use

The balance you purchased is intended to determine the weighing value of material to be weighed. It is intended to be used as a “non-automatic“ balance, i.e. the material to be weighed is suspended on the crane hook only vertically, manually, carefully and without jerks. As soon as a stable weighing value is reached the weighing value can be read.

- Use the crane scales only for lifting and weighing of freely movable loads.
- Danger of injury due to improper use. Not allowed are e.g.:
  - Exceeding the allowed nominal load of crane, crane scales or any type of load attachment devices
  - Conveying persons,
  - Pulling loads over an inclined surface,
  - Tearing-off, pulling or towing loads.
- Modifications or reconstructions of the crane scales or of the crane are not allowed.

## 2.5 Improper Use

Do not use balance for dynamic weighing. In the event that small quantities are removed or added to the material to be weighed, incorrect weighing results can be displayed due to the “stability compensation“. (Example: Slowly draining fluids from a container suspended on the balance.) Do not leave permanent load suspended on the balance. This may damage the measuring system as well as safety-relevant parts.

The balance may only be used according to the described conditions. Other areas of use must be released by KERN in writing.

## 2.6 Warranty

Warranty claims shall be voided in case

- Our conditions in the operation manual are ignored
- The appliance is used outside the described uses
- The appliance is modified or opened
- Mechanical damage and damage caused by media, liquids,
- Natural wear and tear
- The appliance is improperly set up or incorrectly electrically connected
- The measuring system is overloaded

## **2.7 Safe working**

- Do not stand underneath suspended loads!
- Position the crane in a way that the load is lifted vertically.
- When working with the crane and crane scales wear personal safety equipment (helmet, safety shoes etc.).

## **2.8 Monitoring of Test Resources**

In the framework of quality assurance the measuring-related properties of the balance and, if applicable, the testing weight, must be checked regularly. The responsible user must define a suitable interval as well as type and scope of this test. Information is available on KERN's home page ([www.kern-sohn.com](http://www.kern-sohn.com)) with regard to the monitoring of balance test substances and the test weights required for this. In KERN's accredited DKD calibration laboratory test weights and balances may be calibrated (return to the national standard) fast and at moderate cost.

## **2.9 Testing upon acceptance**

When receiving the appliance, please check packaging immediately, and the appliance itself when unpacking for possible visible damage.

## **2.10 Initial Commissioning**

In order to obtain exact results with the electronic balances, your balance must have reached the operating temperature (see warming up time chap. 1).

During this warming up time the balance must be connected to the power supply (mains, accumulator or battery).

The accuracy of the balance depends on the local acceleration of gravity.

Strictly observe hints in chapter Adjustment.

For checking original dimensions, s. chap. 4.2

## **2.11 Shutdown and storage**

- Take off the crane scales from the crane and dismantle all load attachment devices from the crane scales.
- Do not store the crane scales at open air

### 3. The crane scales at a glance

The crane scales are a multi-purpose and cost-saving solution for overhead weighing applications such as e.g. recycling, metal processing, machine engineering, transport and logistics.

With the infrared remote control, operation will be more comfortable yet.

#### 3.1 Overview

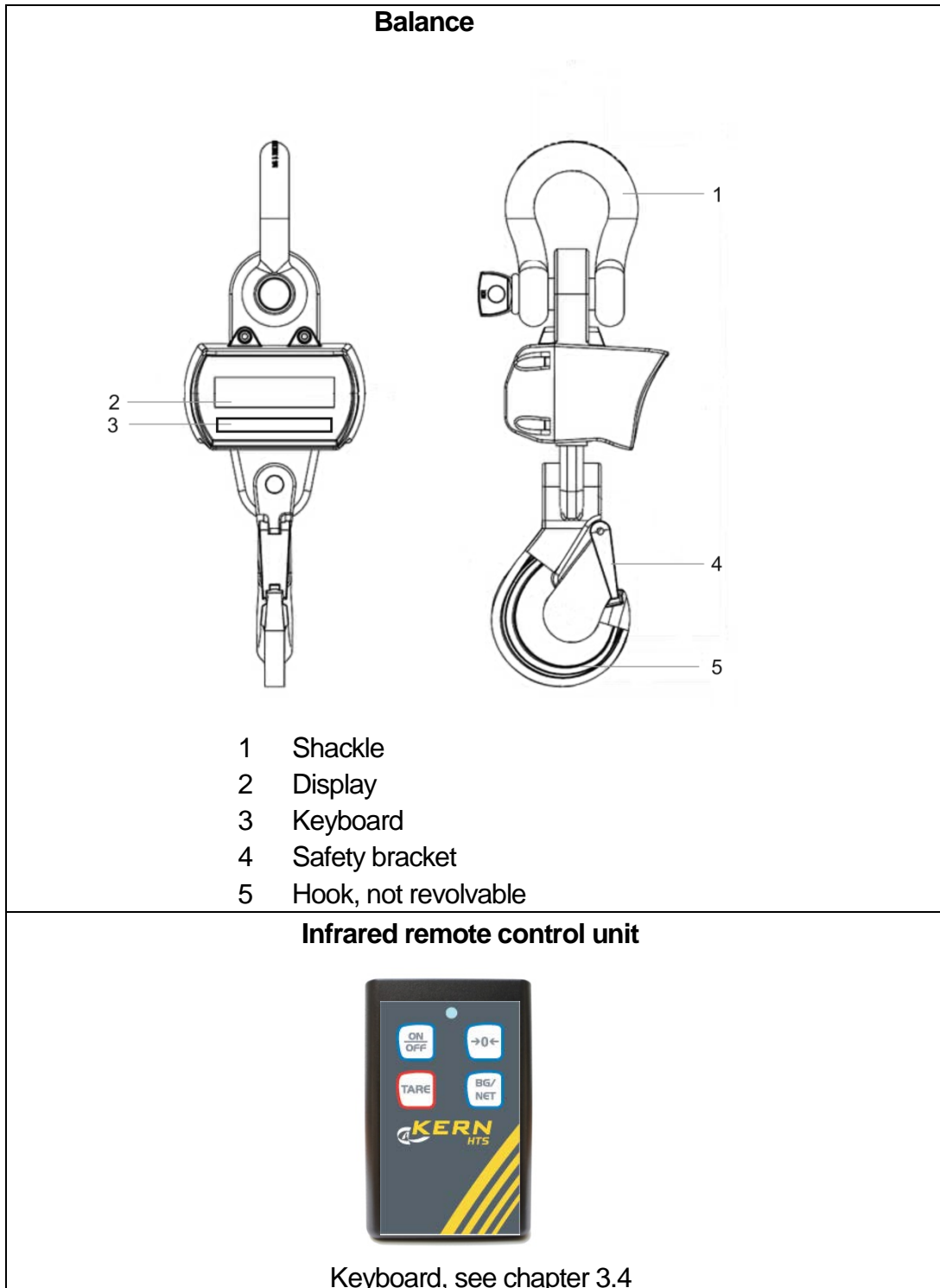

### 3.2 Display

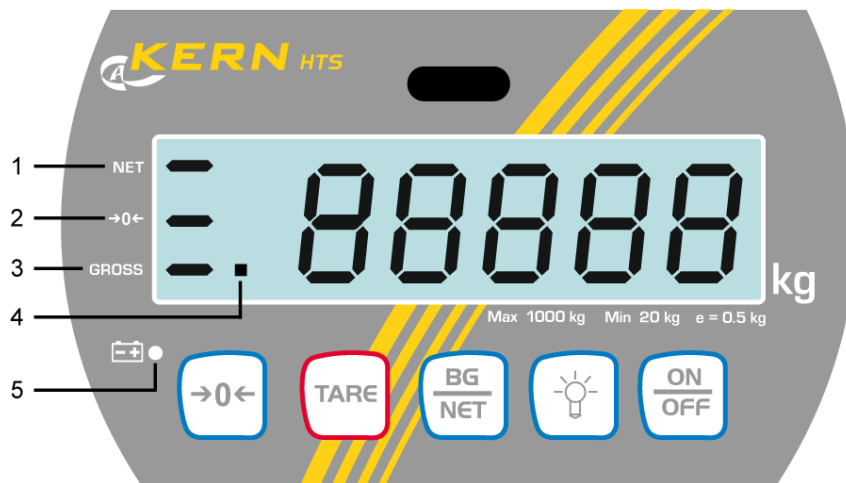

1	Indicator net weight
2	Indicator zero display
3	Indicator gross weight
4	Stability display
5	Battery charge display

### 3.3 Keyboard

Button	Description of function
	<ul style="list-style-type: none"> <li>Zeroing</li> </ul>
	<ul style="list-style-type: none"> <li>Taring</li> </ul>
	<ul style="list-style-type: none"> <li>Gross weight ↔ Net weight</li> </ul>
	<ul style="list-style-type: none"> <li>Background illumination of the display on/off</li> </ul>
	<ul style="list-style-type: none"> <li>Turn on/off balance</li> </ul>





### 3.5 Infrared remote control unit

The balance can be operated by the radio remote control like by a keyboard. All functions (excepted **ON/OFF**) can be selected.

The red LED must light up when any button is pressed. If it does not light up, the batteries in the remote control must be exchanged.

Range on free surface (free of buildings) approx. 10 m.

<b>i</b>	Point the remote control at the balance.
----------	--

		„ON“	Switching on only possible during standby mode of the balance.
		„OFF“	Set balance into stand-by mode
			Zeroing
			Taring
			Gross weight ↔ Net weight

### 3.6 Label



- ⇒ Do not stand or go under suspended loads.
- ⇒ Do not use on building site.
- ⇒ Keep an eye on suspended loads.



(example)

- ⇒ Do not exceed nominal load of crane scales.





- ⇒ The product conforms to the requirements of the German Equipment and Product Safety Act.

## 4. Commissioning

**Attention:** Always observe chapter 2 „General Safety Instructions“!

### 4.1 Unpacking

 <b>SAFETY INSTRUCTIONS</b> for protection against break	<b>Once delivered and unpacked, crane scales will not be taken back.</b>
	The crane scales have been sealed by Messrs. KERN. ⇒ Shackles and hooks are sealed by Sella tape. ⇒ The packaging is also sealed by adhesive tape. <b>+ Broken seal obliges to purchase.</b>
	Thanks for your comprehension. Your KERN Quality assurance team
 <b>VORSICHT</b> Danger for the back!	<b>The crane scales are compact and quite heavy.</b> ⇒ Remove the scales from packaging only with the help of a second person. ⇒ Use a lifting device such as a crane or a forklift truck. ⇒ Secure the scales that they cannot fall down when they are lifted.

Only use original packaging for returning.

⇒ Make sure that all parts are completely present.

- Crane scales
- Mains adapter
- Precision fuse
- Remote control
- Operating instructions (logbook)

### 4.2 Installing a precision fuse

Prior to starting up the balance insert the fuse as shown on the image below.  
Remove the fuse for longer transport or when balance is not in use.



### 4.3 Checking the original dimensions

- ⇒ Enter the original dimensions shown on the production data sheet in the grey boxes of checklist chap. 10.3.
- ⇒ Check original dimension of crane scales; for implementation see chap. 10.2 „Regular Maintenance“
- ⇒ Enter all data (date, tester, results) in the first line under „Inspection before first use“ in the checklist (see chapter 10.3)

 <b>CAUTION</b>	If the dimensions of your first safety inspection do not match those of KERN, the balance must not be put into operation. In this case please contact a service partner authorised by Messrs. KERN.
---	---

### 4.4 Rechargeable battery operation

 <b>CAUTION</b>	<b>Material damage on crane scales</b> <ul style="list-style-type: none"><li>⇒ Only use the delivered mains adapter.</li><li>⇒ Make sure that the mains adapter, the cable and the mains plug are in a perfect condition.</li><li>⇒ Do not use the crane scales during the loading process.</li></ul>
--	---

Before the first use, the rechargeable battery should be charged by connecting it to the mains power cable for at least 24 hours. The operating time of the rechargeable battery is approx. 100 hours.

If the capacity of the rechargeable battery is exhausted, „**LOb**“ appears. The balance will be ready to operate for about another 10 minute, then it will switch off automatically. Connect the power cable as soon as possible to load the rechargeable battery.

When the crane scales are out of operation for a longer period, remove the rechargeable battery.

## 4.5 Suspending the balance

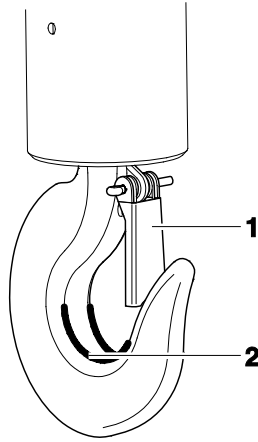

### Condition

The crane needs a safety bracket (1) that the unloaded crane scales cannot fall down.





If the safety bracket is missing or damaged, please contact the crane manufacturer in order to receive a hook with this safety equipment.

⇒ Suspend the crane scales on the lower hook of a crane and close the safety bracket.

The crane scale's upper eyelet should rest in the saddle (2).

## 5. Operation

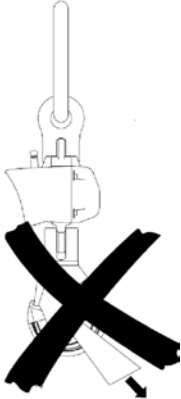
### 5.1 Safety instructions

	 <p><b>Risk of injury due to falling loads!</b></p> <p><b>Danger</b></p>
   	<ul style="list-style-type: none"><li>⇒ Take great care when operating the crane and follow the general rules for crane operation.</li><li>⇒ Check all parts (hook, eyelet, rings, rope slings, cables, chains etc.) for excessive wear or damage</li><li>⇒ If faults can be seen on the safety bracket of the hook or if it is missing completely, the scales must not be used</li><li>⇒ Work only with appropriate speed</li><li>⇒ Always avoid vibrations and horizontal forces. Avoid any kind of shock, torsion and oscillating (e.g. caused by inclined suspending)</li><li>⇒ Do not use the crane scales for transporting loads.</li> <li>⇒ Do not stand or go under suspended loads.</li> <li>⇒ Do not use on building site.</li></ul>

 <p>(example)</p>	<ul style="list-style-type: none"> <li>⇒ Keep an eye on suspended loads.</li> <li>⇒ Do not exceed the nominal load of crane, crane scales or any kind of load attachment devices at the crane scales.</li> </ul>
--	--

## 5.2 Loading the crane scales

For good weighing results observe the following, illustrations see next page:

- ⇒ Only use load attachment devices which guarantee a one-spot suspension and where the scales can be suspended freely.
- ⇒ Do not use too large load attachment devices which do not guarantee any one-spot suspension.
- ⇒ Do not use multiple suspensions.
- ⇒ Do not pull or push the load or the loaded balance.
- ⇒ Do not pull the hook horizontally.

### Loading the balance

1. Position the hook of the crane scales over the load.
2. Move downwards the crane scales until the load can be suspended on the hook of the balance. Reduce the speed when the respective height is going to be reached.
3. Suspend the load on the hook. Ensure that the safety bracket is closed. If the load is fixed by slings, ensure that the slings rest completely on the saddle of the balance hook.
4. Lift-off the load slowly.

When the load is fixed by slings, ensure that the load is well balanced on both sides and that the slings are correctly positioned

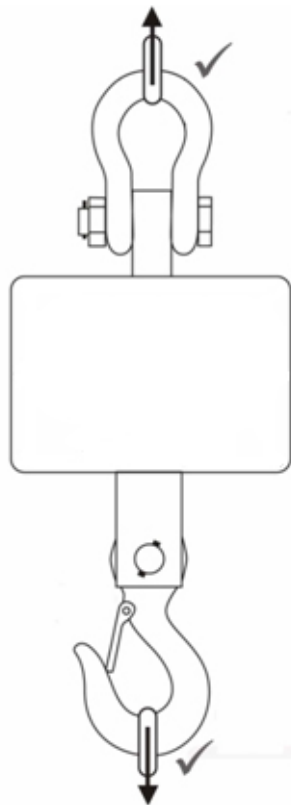

**Only use load attachment devices which guarantee a one-point suspension and where the scales can be suspended freely.**

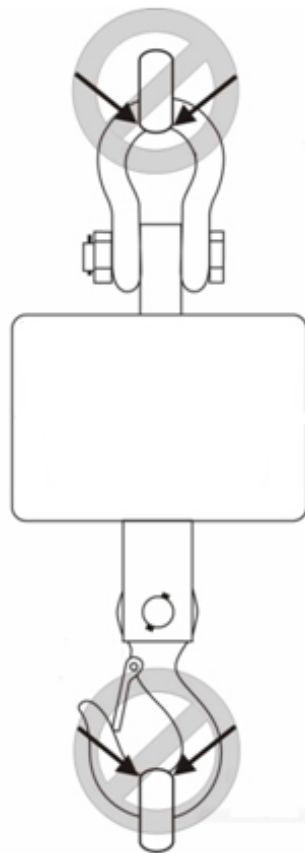

**Do not use too large load attachment devices which cannot guarantee a one-point suspension.**

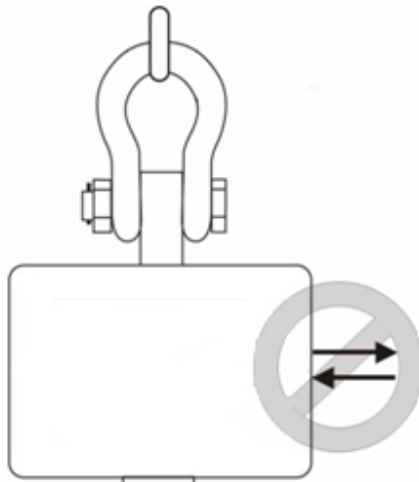

**Do not push or pull**



**Do not pull the hook horizontally**

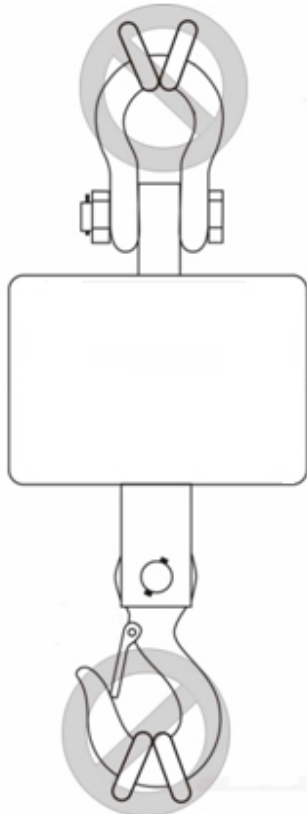

**Do not use multiple suspensions**

## 5.3 Turn on/off

### Start-up

⇒ Press  on the keyboard of the balance. The display lights up and the balance carries out a selftest. The display runs through “PoUP2→„ESC2“→„8.8.8.88“, followed by the battery loading status (e.g. “CH5“ corresponds to a battery loading status of 50%) and the check number of adjustments. The selftest is completed when the weight value 0 appears on the display.

#### Battery loading status:

The battery loading status is represented in the form of “CH .x“, such as

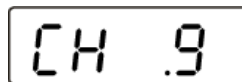

This corresponds to a battery loading status of 90%.

#### Check number:

<b>i</b>	<b>For verified balances pay attention to check number!</b> The check number will be shown after the balance has been turned on. This number will be adjusted automatically after each adjustment activity. In verified balances this number is an integral part for conformity evaluation. This allows you to check at any time whether new adjustment has been carried out.
----------	--

To display the check number, turn the balance off and then restart it with . The display shows successively e.g.:

8.8.8.8	Check LCD segments
CH .9	Battery loading status (example: CH .9 corresponds to a battery loading status of 90%)
8985	Check number

<b>i</b>	<ul style="list-style-type: none"><li>• Switching on/off only possible on the keyboard of the balance.</li><li>• Using the remote control unit, the balance can only be switched on from the standby mode.</li></ul>
----------	--

## Switching Off

⇒ Press  on the keyboard of the balance.  
**or**

⇒ Press  on the keyboard of the remote control unit, the balance is in standby mode.

### 5.4 Set balance to zero

In order to obtain optimal weighing results, reset to zero the balance before weighing.

Unload the balance

Press .

In the display appears 0 (kg) and the indicator next to **a** lights up.

## 5.5 Taring

⇒ Suspend preload.

Wait for stability display, then press . In the display appears 0 (kg) and the indicator next to „**NET**“ appears. The weight of the container is now internally saved.

⇒ Weigh the material, the net weight will be indicated.

⇒ After removing the preload weight appears as negative display.

⇒ To delete the tare value, remove load from crane balance and press .

## 5.6 Weighing

⇒ Loading the crane scales.

The weight value will be displayed at once.



### Overload warning

Overloading exceeding the stated maximum load (max) of the balance, minus a possibly existing tare load, must be strictly avoided. This could cause damage to the balance.

Exceeding the maximum load is indicated by the display „--OL-“. Unload balance or reduce preload.

## 5.7 Gross / net invocation

By repeated pressing of , change between gross and net display values. In the „Gross weight“ display the indicator appears next to **GROSS**. In the „Net weight“ display the indicator appears next to **NET**.

## 5.8 Display background illumination

⇒ Press , the display will appear backlit.

⇒ Press  again, the background illumination of the display will extinguish.

## 7. Adjustment and verification

### 7.1 Adjustment

As the acceleration value due to gravity is not the same at every location on earth, each balance must be coordinated - in compliance with the underlying physical weighing principle - to the existing acceleration due to gravity at its place of location (only if the balance has not already been adjusted to the location in the factory). This adjustment process must be carried out for the first commissioning, after each change of location as well as in case of fluctuating environment temperature. To receive accurate measuring values it is also recommended to adjust the balance periodically in weighing operation.



- The weight to be used depends on the capacity of the scale. Carry out adjustment as near as possible to the scale's maximum weight. Info about test weights can be found on the Internet at: <http://www.kern-sohn.com>.
- Observe stable environmental conditions. A warming up time (see chapter 1) is required for stabilization.

### Models with type approval

The adjustment procedure is described in separate instructions. They can be found under <http://www.kern-sohn.com>.

## 7.2 Verification

### General introduction:

According to EU directive 2009/23/EC balances must be officially verified if they are used as follows (legally controlled area):

- a) For commercial transactions if the price of goods is determined by weighing.
- b) For the production of medicines in pharmacies as well as for analyses in the medical and pharmaceutical laboratory.
- c) For official purposes
- d) For manufacturing final packages

In cases of doubt, please contact your local trade in standard.

### Verification notes:

An EU type approval exists for balances described in their technical data as verifyable. If a balance is used where obligation to verify exists as described above, it must be verified and re-verified at regular intervals.

Re-verification of a balance is carried out according to the respective national regulations. The validity for verification of balances in Germany is e.g. 2 years.

The legal regulation of the country where the balance is used must be observed!

<b>i</b>	<b>Verification of the balance is invalid without the seal.</b> The seal marks attached on balances with type approval point out that the balance may only be opened and serviced by trained and authorised specialist staff. If the seal mark is destroyed, verification loses its validity. Please observe all national laws and legal regulations. In Germany a re-verification will be necessary.
----------	--

<b>i</b>	<b>For verified balances pay attention to check number!</b> The check number will be shown after the balance has been turned on. This number will be adjusted automatically after each adjustment activity. In verified balances this number is an integral part for conformity evaluation. This allows you to check at any time whether new adjustment has been carried out.
----------	--

To display the check number, turn the balance off and then restart it with .  
The display shows successively e.g.:

8.8.8.8.8	Check LCD segments
CH .9	Battery loading status (example: CH .9 corresponds to a battery loading status of 90%)
8985	Check number

The verification is not valid, when the check number of the system does not match with the check number on the type plate.

## 8. Error messages

Error message	Description	Possible causes
--oI-	Maximum load exceeded	<ul style="list-style-type: none"> <li>⇒ Reduce load</li> <li>⇒ Check whether the balance has been damaged</li> </ul>
LOb	<p>Capacity of rechargeable battery exhausted.</p> <p>In the „LOB“ display, the balance switches off automatically to save the rechargeable battery after 1 minute.</p>	<ul style="list-style-type: none"> <li>⇒ Recharge battery</li> </ul>

Should other error messages occur, switch balance off and then on again. If the error message remains inform manufacturer.

## 9. Cleaning and Disposal

### 9.1 Cleaning and Disposal

 <b>CAUTION</b>	<p><b>Damage on the crane balance!</b></p> <ul style="list-style-type: none"> <li>⇒ Do not use any industrial solutions or chemicals</li> </ul>
---	---

- ⇒ Clean the keyboard and the display with a soft cloth soaked in mild window cleaning agent.
- ⇒ Disposal of packaging and appliance must be carried out by operator according to valid national or regional law of the location where the appliance is used.

## 10. Maintenance and repair

 <p><b>Danger</b></p>	<p><b>Risk of injury and risk of material damage!</b> <b>The crane scales are part of a hoisting device!</b> <b>For a safe operation please observe the following:</b></p> <ul style="list-style-type: none"><li>⇒ Have carried out a regular maintenance by trained specialized staff</li><li>⇒ Carry out regular maintenance and care, see chapter 10.2 and 10.3</li><li>⇒ Have the parts exchanged only by trained specialized staff.</li><li>⇒ If there arose discrepancies with the safety checklist, the balance must not more be put into operation.</li><li>⇒ Do not repair the crane scales by yourself. Repair may only be carried out by service partners authorized by Messrs. KERN.</li></ul>
--	--

### 10.1 Regular maintenance and care

- ▲ The regular 3-month maintenance may only be carried out by an expert with competent knowledge of working with crane scales. Thereby the national regulations for prevention of accidents as well as the working, operation and safety regulations of the owner-operator.
- ▲ To check the dimensions only use suitable test devices.
- ▲ The regular 12-month maintenance must only be carried out by trained specialized staff (KERN customer service).
- ▲ The results of the maintenance must be written down in the checklist (chap. 10.3).
- ▲ The additional results of the extended maintenance have to be entered in the checklist (chapter 11.1).
- ▲ The replaced spare parts also must be entered, (chapter 11.2)

## 10.2 Regular maintenance

<p><b>Initial start-up,</b> every <b>3 months</b> or definitely after <b>12 500 weighing</b> <b>processes</b></p>	<ul style="list-style-type: none"> <li>▪ Check all dimensions, see checklist chap. 9.2</li> <li>▪ Check the shackle for wear and tear, such as e.g. plastic deformation, mechanical damage (unevenness), notches, striation, cracks, corrosion, thread damage and torsions.</li> <li>▪ Check the application of the safety bracket on the hook, moreover check for fault and correct function</li> <li>▪ Check that the split pin and the nut on the shackle are not loose</li> </ul> <p>If a dimension exceeds the admitted deviation from the original dimension (see checklist, chap. 10.3) or if other discrepancies have been found, the balance must be repaired at once by trained specialized staff (KERN customer service). Never do repair it by yourself! Take balance out of operation immediately!</p> <p>All repairs and spare parts must be documented by the service partner (see list, chap. 11.2).</p>
<p>Every <b>12 months</b> or in any case after <b>50 000 weighing</b> <b>processes</b></p>	<ul style="list-style-type: none"> <li>▪ If the enhanced maintenance has to be carried out by trained staff (KERN customer service). At this general revision all load carrying parts must be checked for gaps with magnetic powder</li> </ul>
<p>Every <b>5 years</b> or anyway after <b>250 000 weighing</b> <b>processes</b></p>	<ul style="list-style-type: none"> <li>▪ All load carrying parts have to be exchanged by trained specialized staff (KERN customer service).</li> </ul>
<p>Every <b>10 years</b> or anyway after <b>500 000 weighing</b> <b>processes</b></p>	<ul style="list-style-type: none"> <li>▪ Replace the crane balance entirely</li> </ul>

### Note

During the revision watch out for wear and tear according to the following drawings (chap. 10.3).

### 10.3 Checklist „Regular maintenance“, (see chapter 10.2)

<b>Original dimensions suspended balance*, serial no.:</b> .....												<b>Capacity</b> .....	
<b>Shackle</b>					<b>Hooks</b>					<b>Anchor eyelets</b>			
a (mm)	b (mm)	c (mm)	Wear and tear	Split pin&Nut	d (mm)	e (mm)	Wear and tear	Angle $\alpha$ (°)	f (mm)	g (mm)	h (mm)		
<b>Date</b> .....				<b>Tester</b> .....									

**\*These data can be found in the document attached to the balance. Please keep this document always available.**

	Shackle					Hooks				Anchor eyelets			Date	Tester
	a	b	c	Wear and tear (see grey fields)	Split pin& Nut	d	e	$\alpha$	Wear and tear (see grey fields)	f	g (Ø)	h (Ø)		
Max. admitted variation	5 %	0%	5 %	No deformation or cracks	tight	10%	5 %	10 °	No deformation or cracks	1%	1%	1%		
Revision prior to first use														
3 months/12,500 x														
6 months/25,000 x														
9 months/37,500 x														
<b>12 months/50,000 x</b>														
15 months/62,500 x														
18 months/75,000 x														
21 months/87,500 x														

	Shackle					Hooks				Anchor eyelets				
	a	b	c	Wear and tear (see grey fields)	Split pin& Nut	d	e	$\alpha$	Wear and tear (see grey fields)	f	g (Ø)	h (Ø)	Date	Tester
Max. admitted variation	5 %	0%	5 %	No deformation or cracks	tight	10%	5 %	10 °	No deformation or cracks	1%	1%	1%		
Revision prior to first use														
<b>24 months/100,000 x</b>														
27 months/112,500 x														
30 months/125,000 x														
33 months/137,500 x														
<b>36 months/150,000 x</b>														
39 months/162,500 x														
42 months/175,000 x														
<b>48 months/200 000</b>														
51 months/212,500 x														
54 months/225,000 x														
57 months/237,500 x														
<b>60 months/250 000x</b>	➔ All load carrying parts have to be exchanged by a service partner authorised by KERN.													

**bold letters** = this maintenance work has to be carried out by a service partner authorized by KERN.

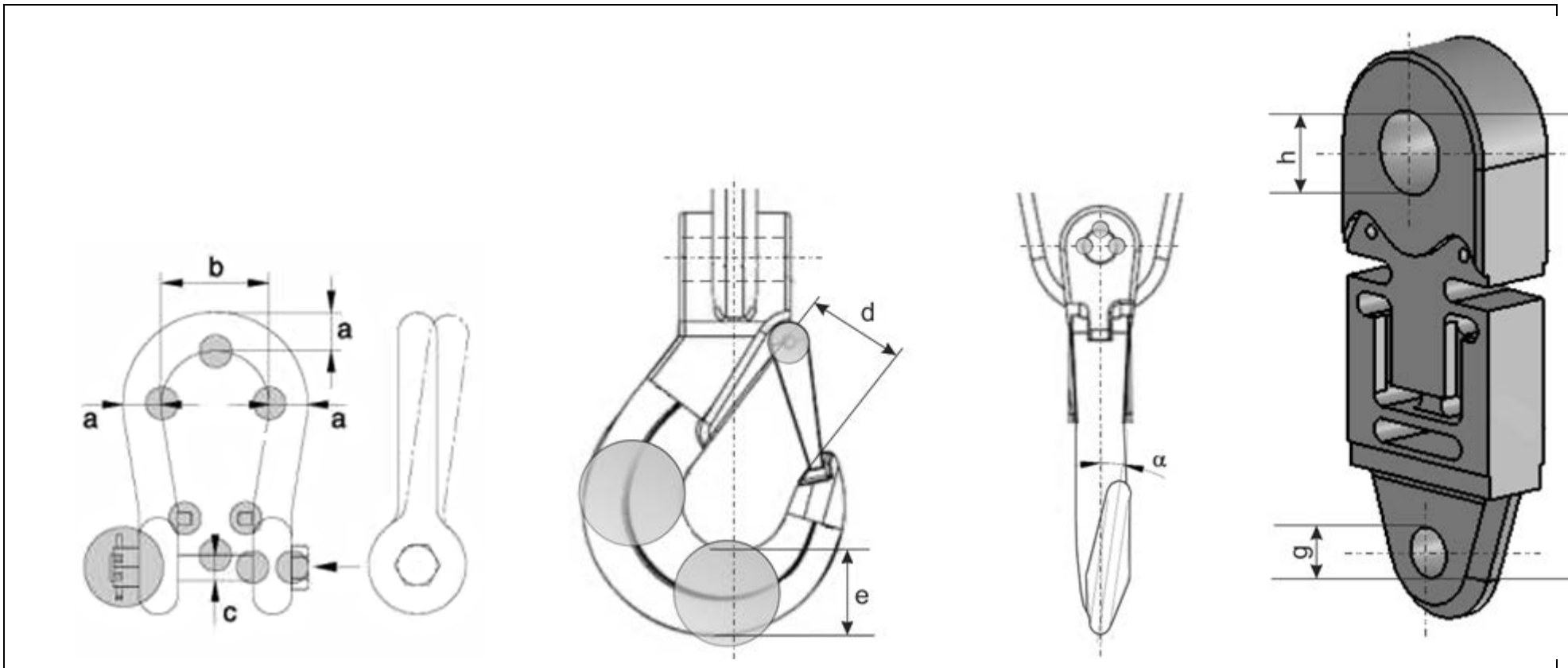

## 11. Enclosure

### 11.1 Checklist „Enhanced maintenance“ (General revision)

The enhanced maintenance has to be carried out by a service partner authorized by KERN.

Crane scales		Model ..... Serial no. ....					
Interval	Magnetic powder test for cracks	Shackle	Hooks	Anchor eyelets	Date	Name	Signature
12 months/50,000 x							
24 months/100,000 x							
36 months/150,000 x							
48 months/200,000 x							
60 months/250,000 x							
72 months/300,000 x							
84 months/350,000 x							
96 months/400,000 x							
108 months/450 000 x							
120 months/500 000x	➔ Replace crane scales entirely						

### 11.2 List „spare parts and repair of safety-relevant parts“

Repair has to be carried out by a service partner authorized by KERN.

<b>Crane scales</b>	Model ..... Serial no. ....			
<b>Part</b>	<b>Action</b>	<b>Date</b>	<b>Name</b>	<b>Signature</b>

